

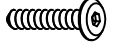

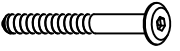

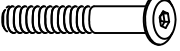

Thank you for purchasing this quality product. Be sure to check all packing material carefully for small parts, which may have come loose inside the carton during shipment. Identify and count all parts and compare with the Hardware List below.

KITCHEN ISLAND W/ WOOD TOP	No.	Description	Qty
	A	Top & Drawer Box	1
	B	Leg Right	1
	C	Leg Left	1
	D	Panel Shelf	2
	E	Partition Up	1
	F	Bottom Shelf	1
	G	Back Panel	1
	H	Caster with lock	2
	I	Caster	2
	J	Handle pull	1

HARDWARE	No.	Picture	Description	Dimension	Qty
	1		Short bolt	M6 x 25 mm	20
	2		Long bolt	M6 x 40 mm	18
	3		Large bolt	M8 x 40 mm	2
	4		Lock washer	Ø13xØ6x1 mm	38
	5		Flat washer	Ø16xØ6.5x1 mm	38
	6		Short screw	Ø6 x 1/2"	8
	7		Long screw	Ø16 x 5/8"	5
	8		Pin shelf		8
	9		Z - Allen key	L4	1

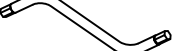
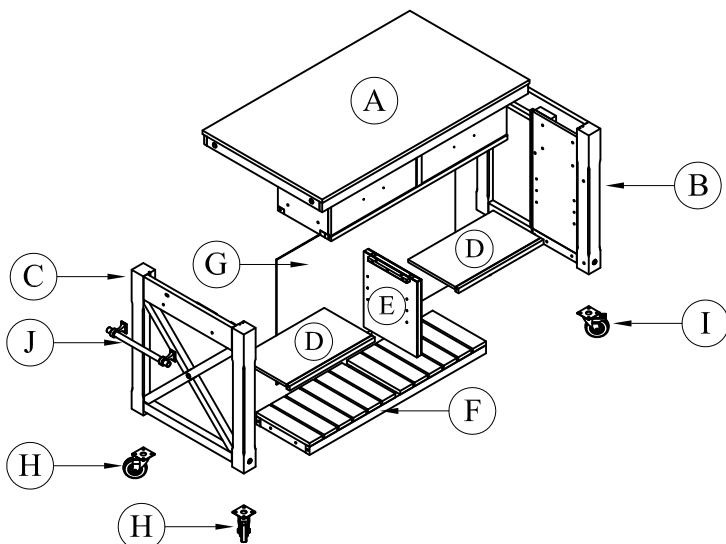

Assembly step 1

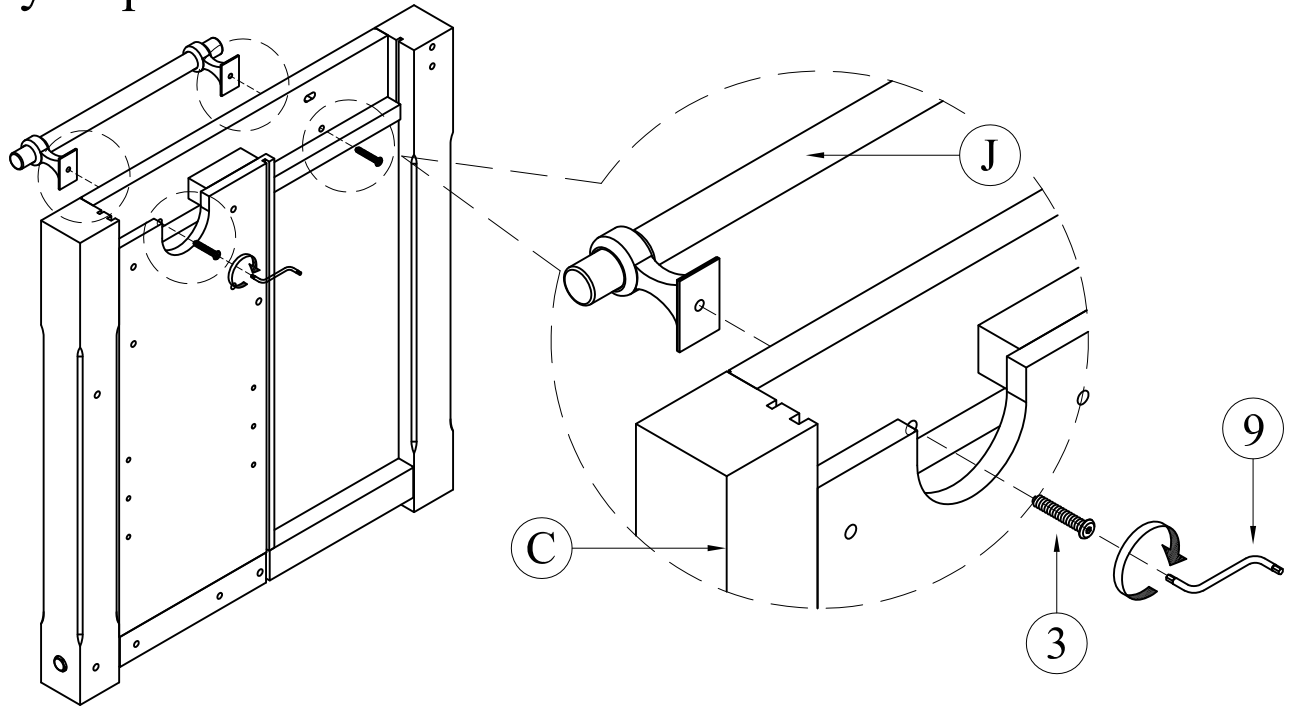

Assembly step 2

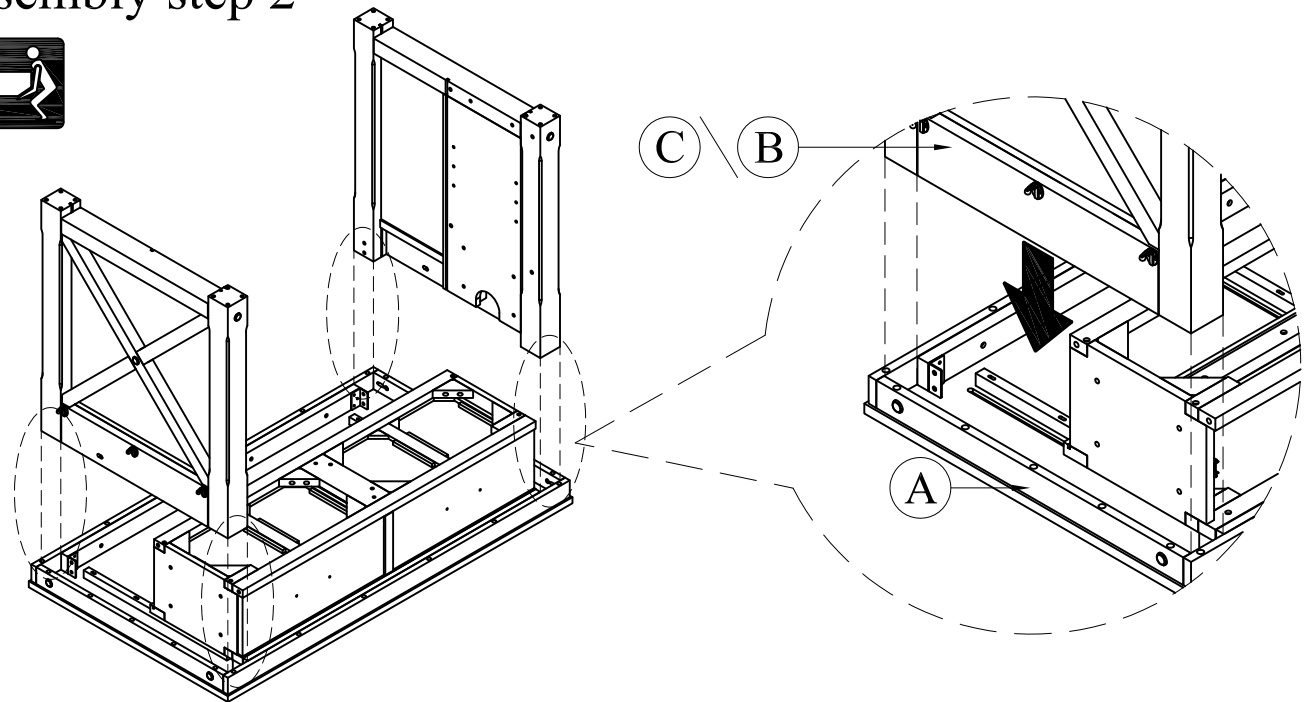

Assembly step 3

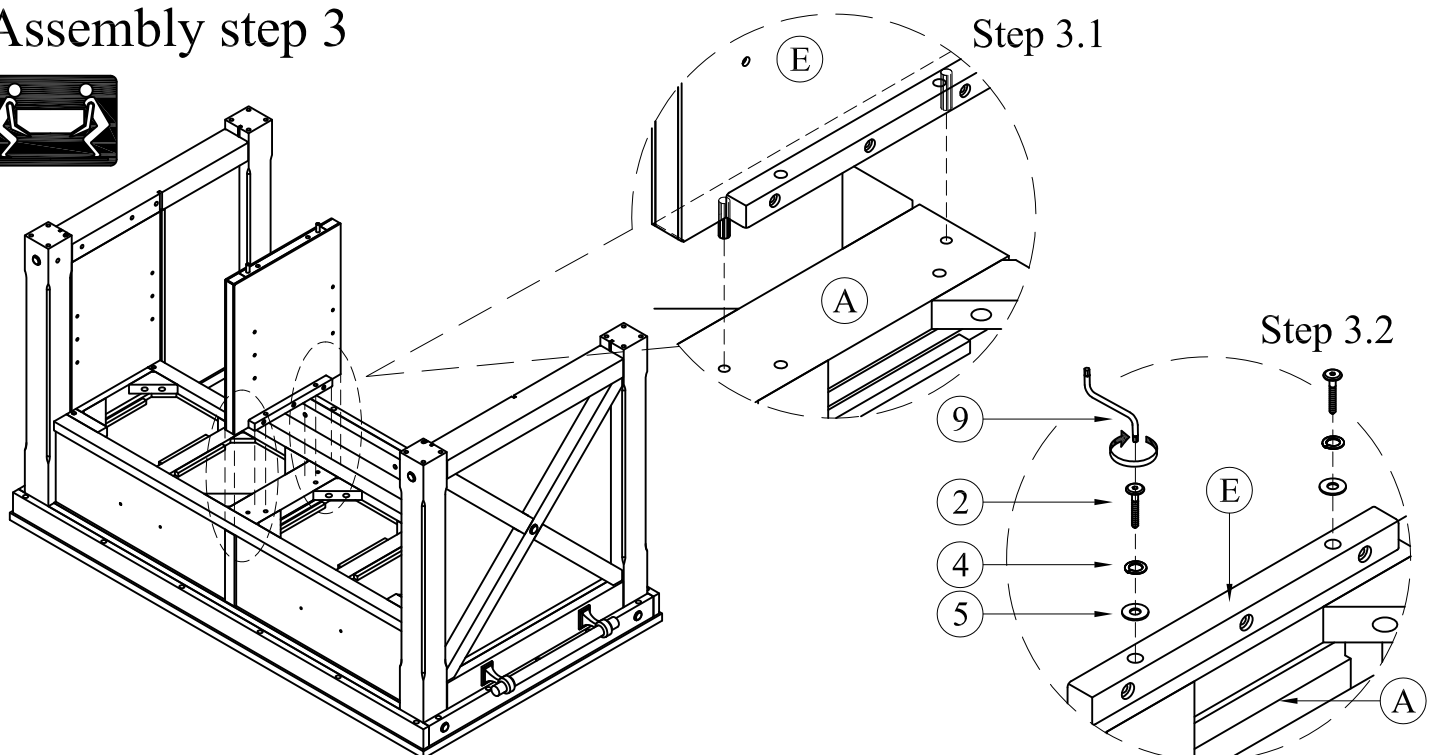

Assembly step 4

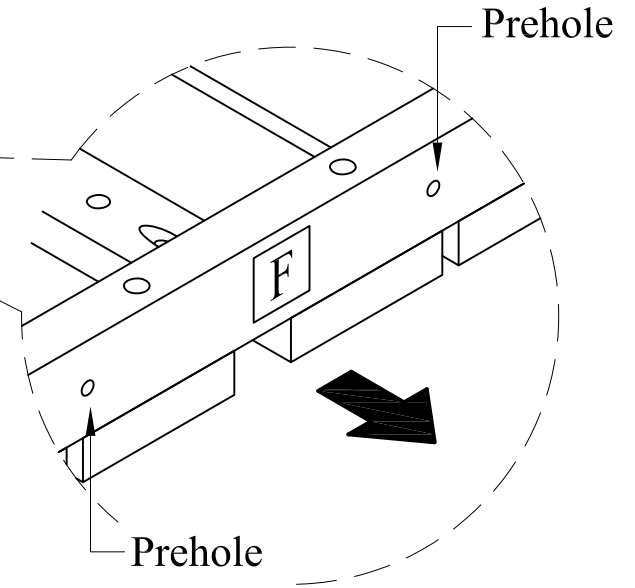
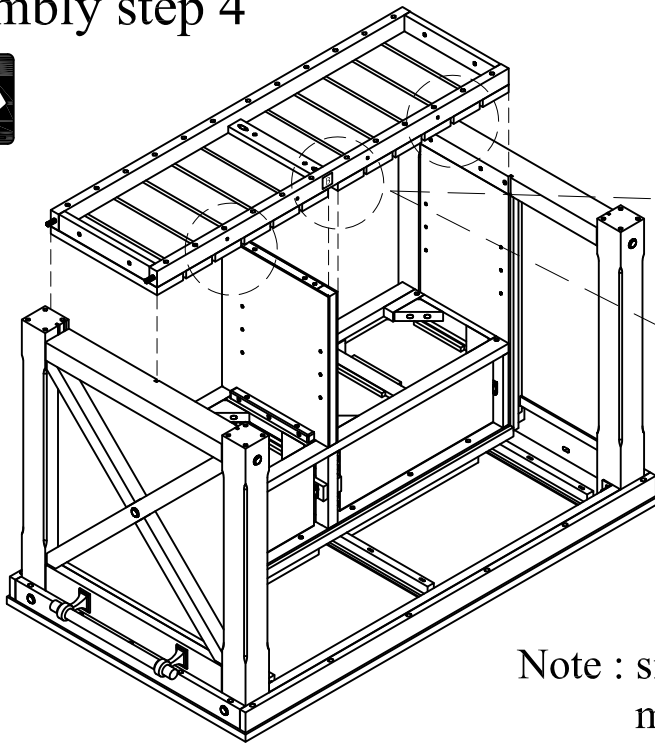

Note : side of bottom shelf (F) with prehole must be looked on the back view.

Assembly step 5

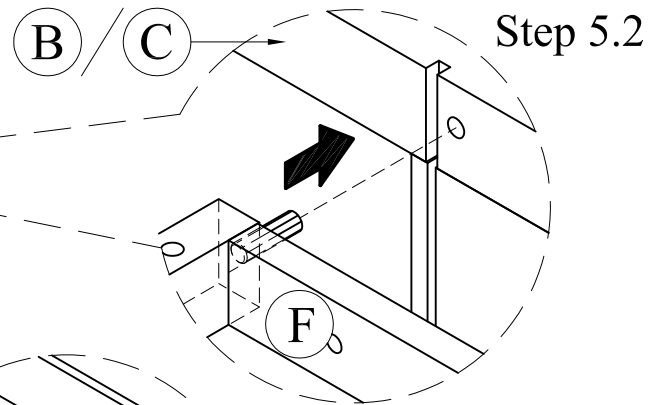
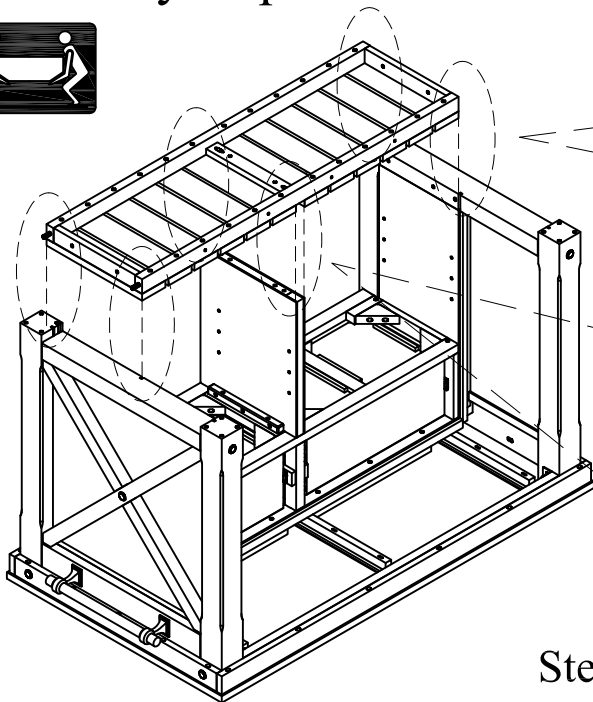

Step 5.1

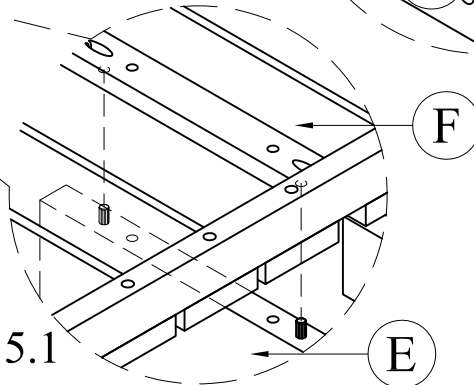

Assembly step 6

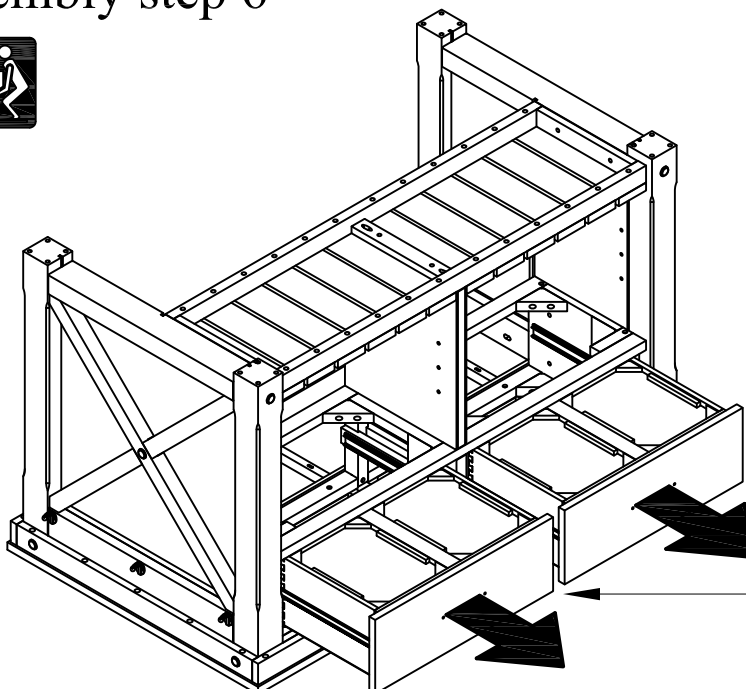

Slightly pull out the drawer box
Do not pull out until loose or remove.

Assembly step 7

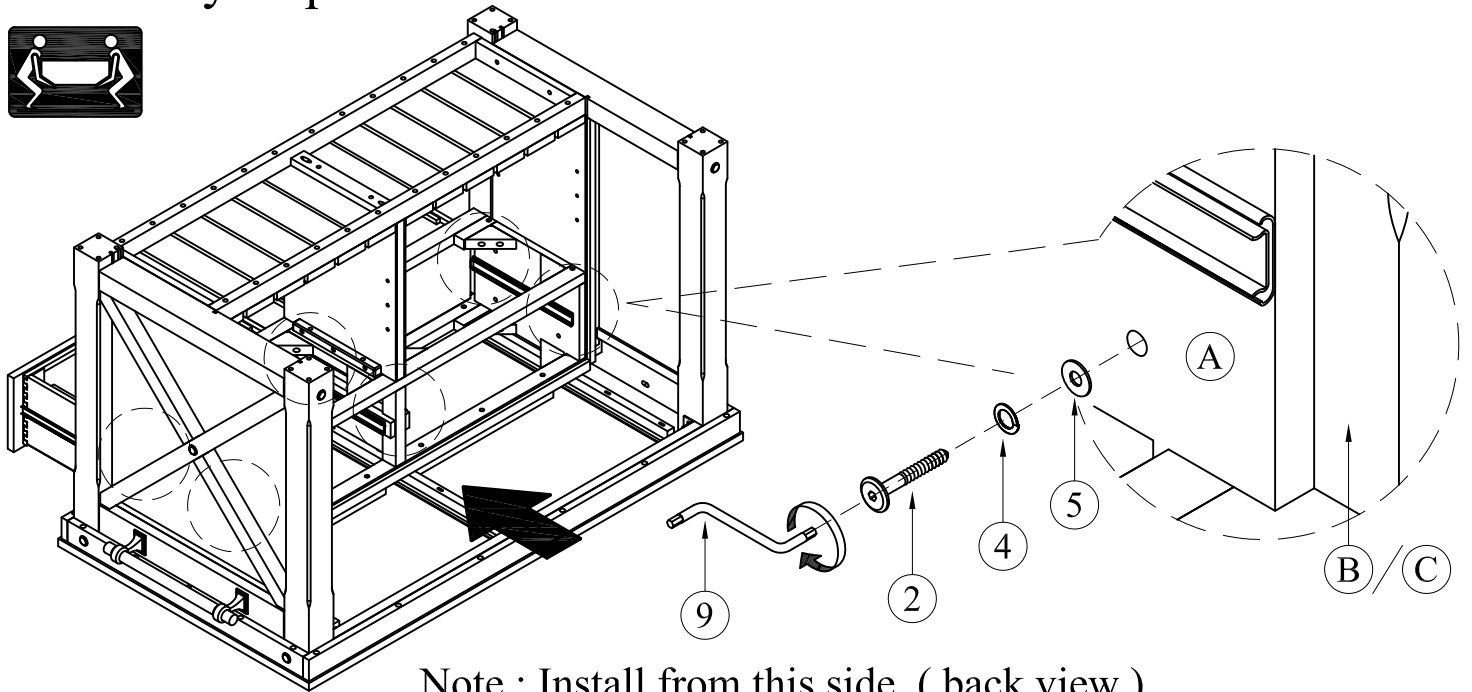

Note : Install from this side. (back view)

Assembly step 8

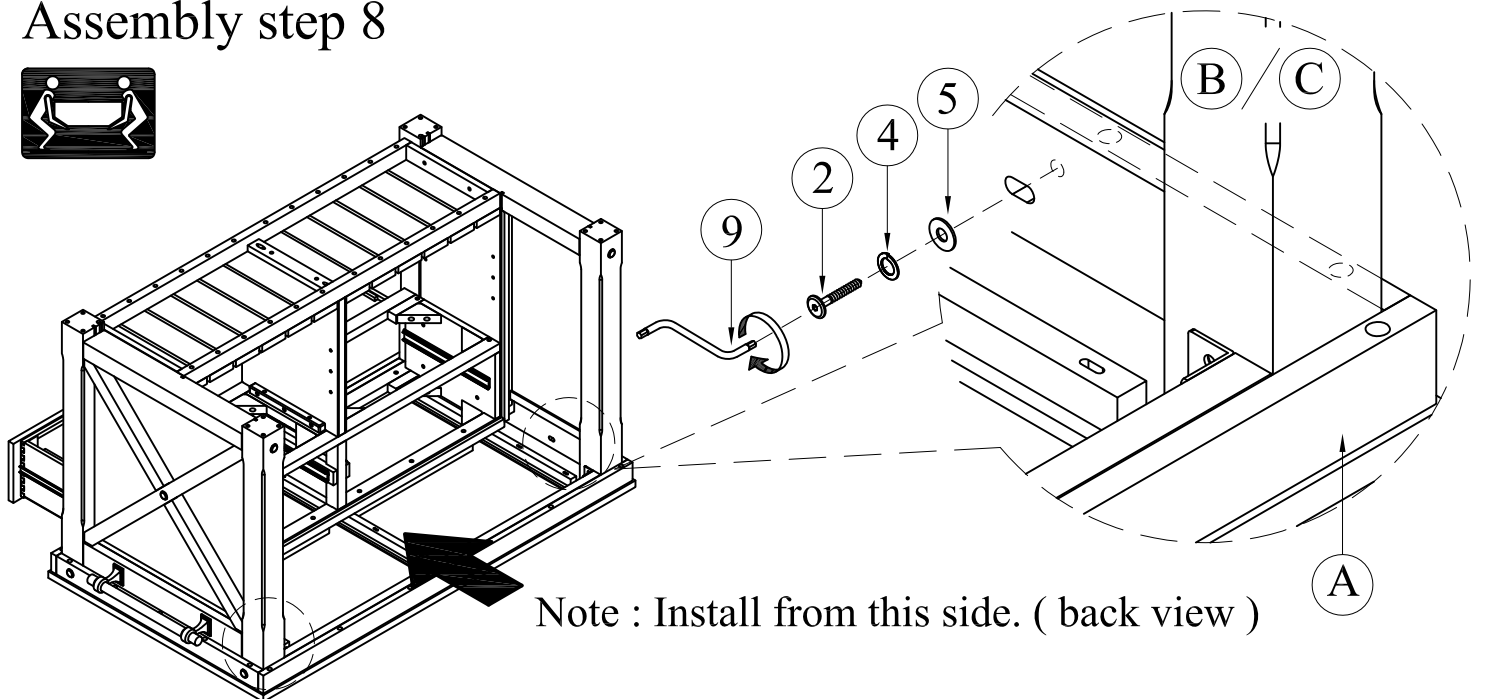

Note : Install from this side. (back view)

Assembly step 9

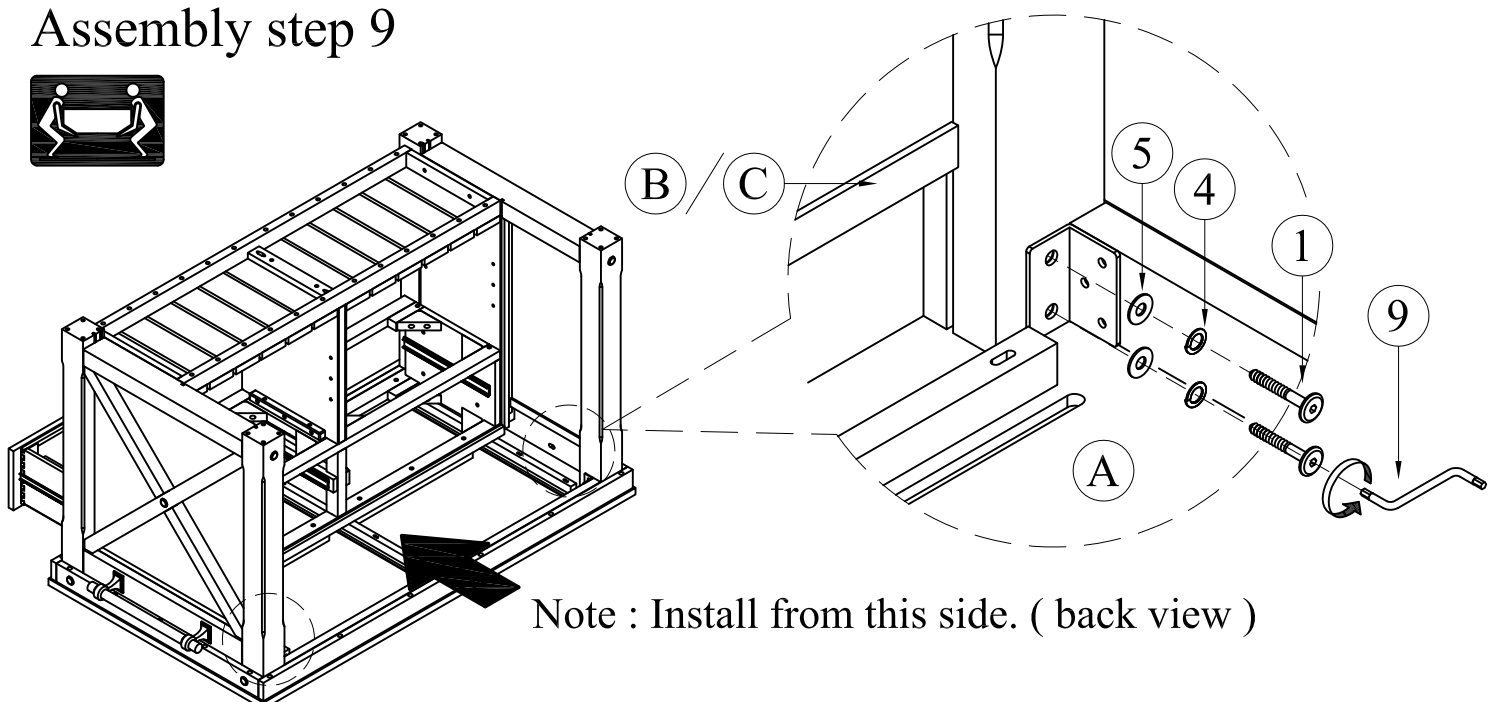

Note : Install from this side. (back view)

Assembly step 10

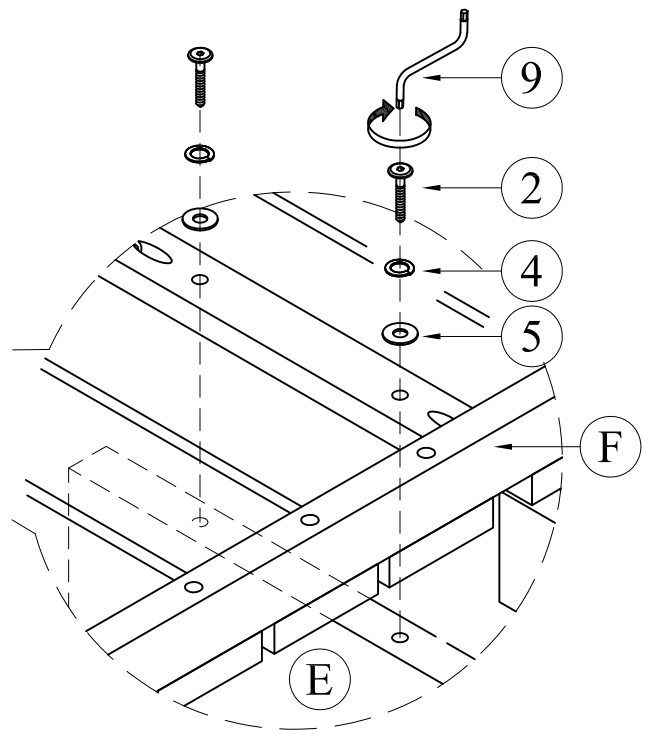
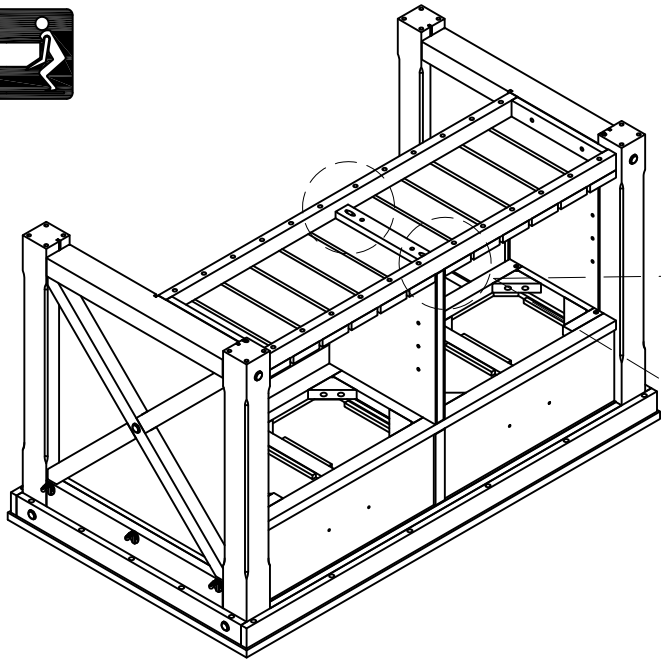

Assembly step 11

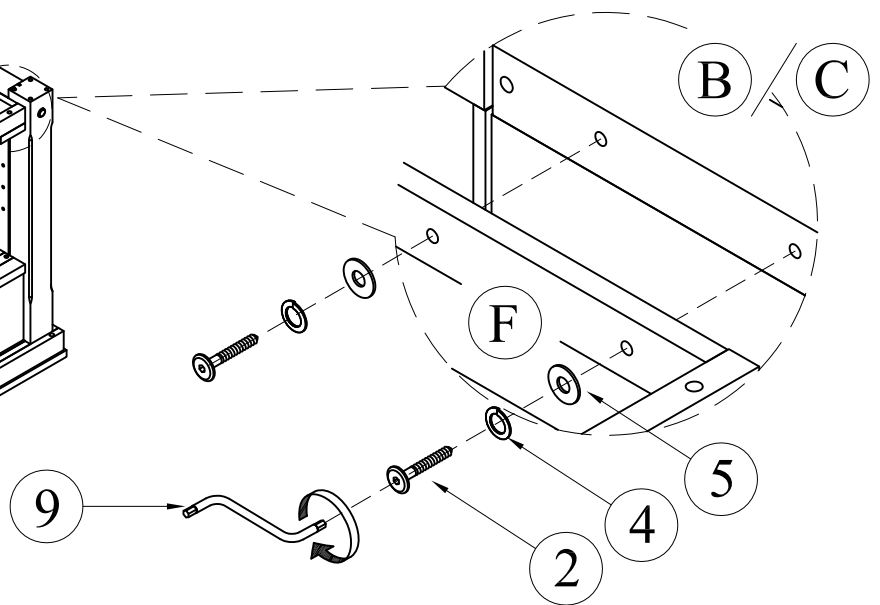
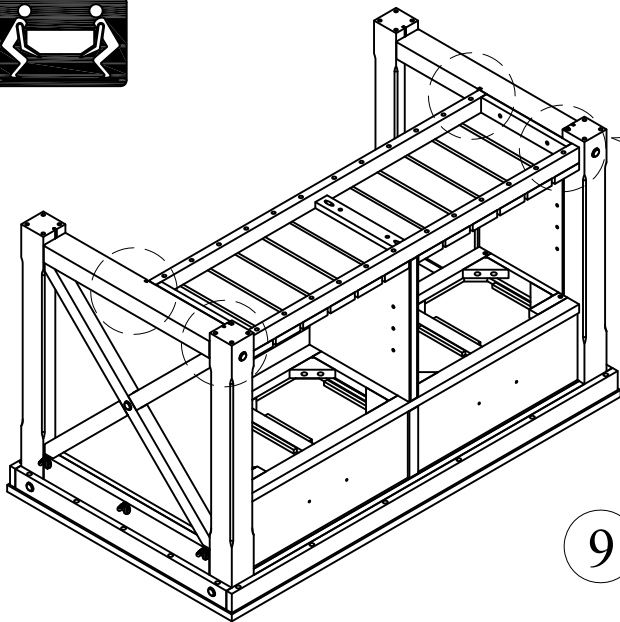

Assembly step 12

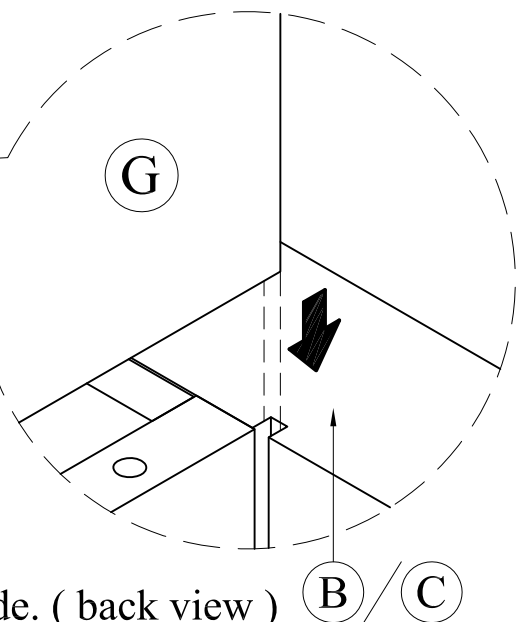
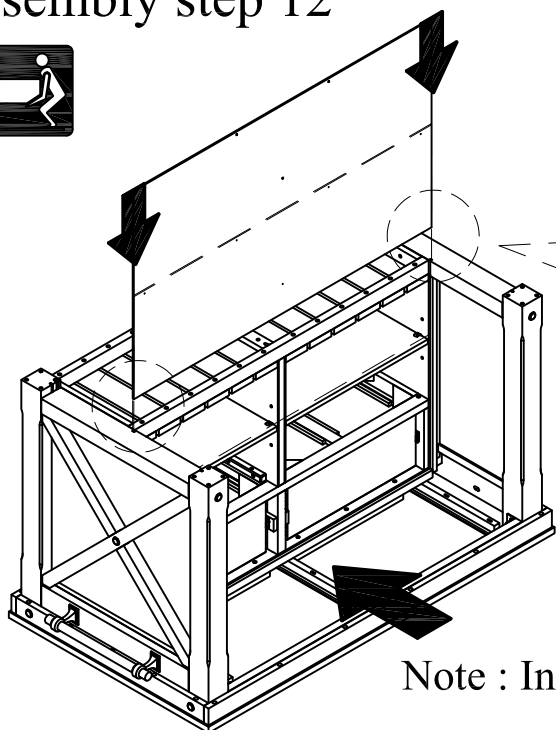

Note : Install from this side. (back view)

Assembly step 13

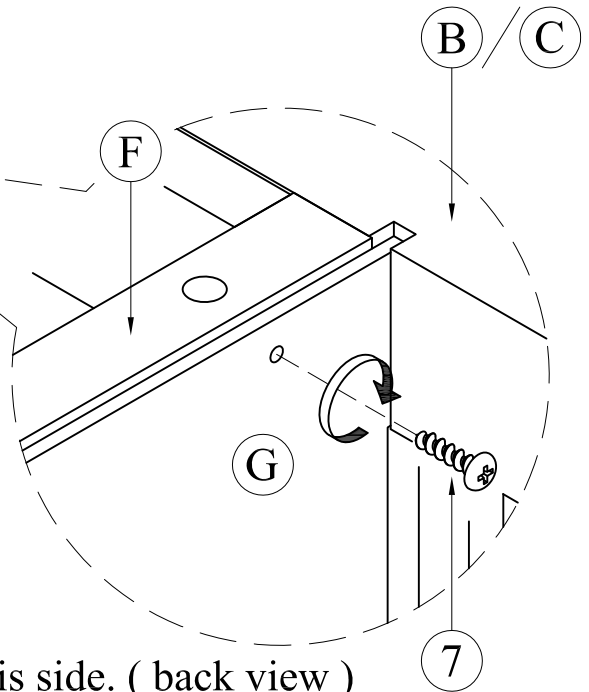
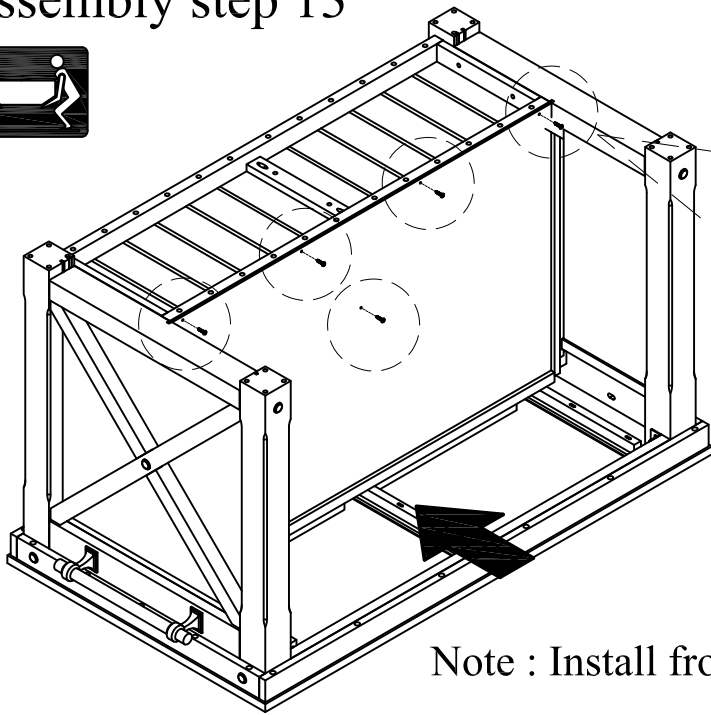

Note : Install from this side. (back view)

Assembly step 14

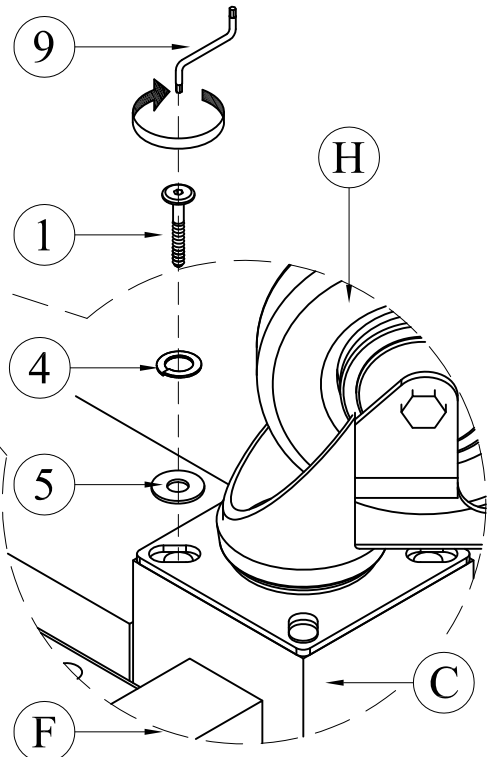
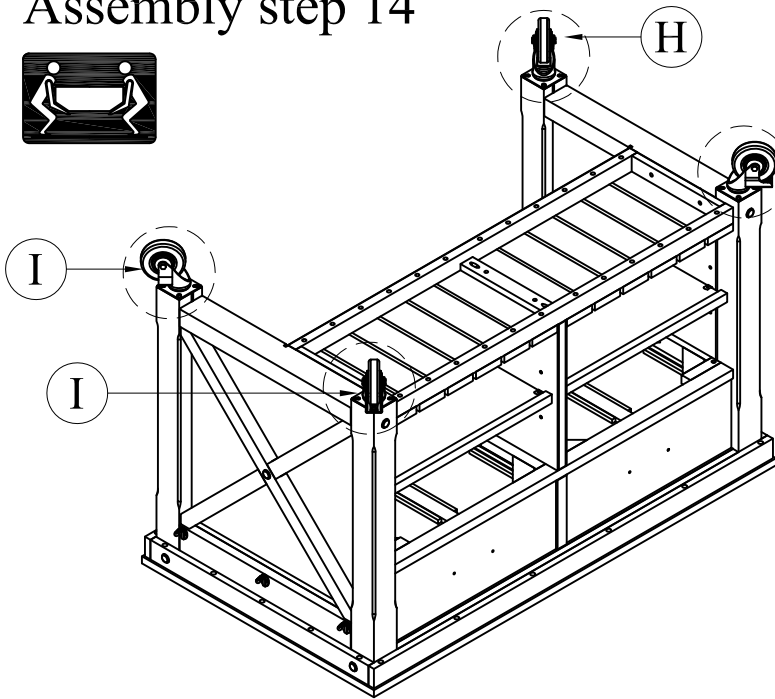

Assembly step 15

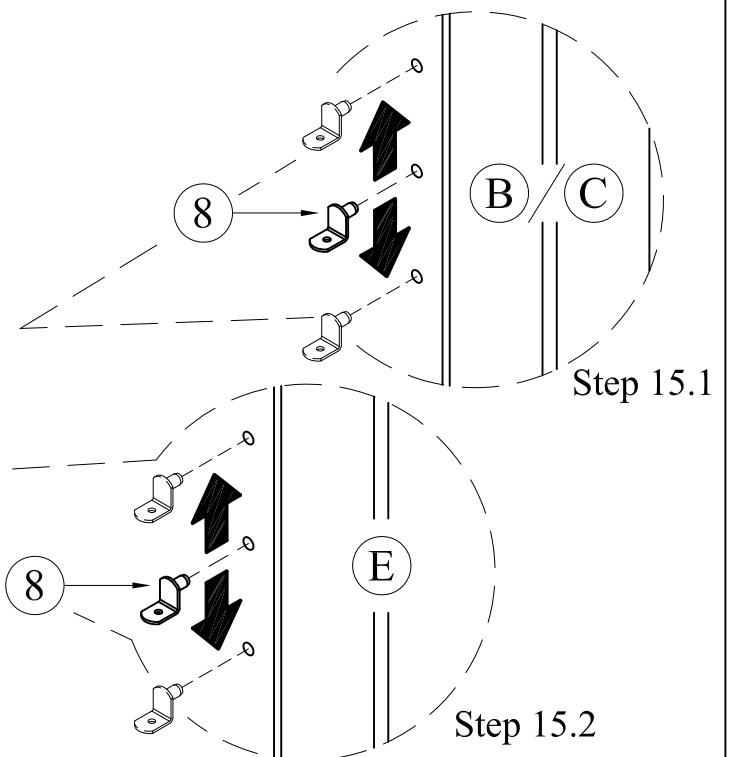
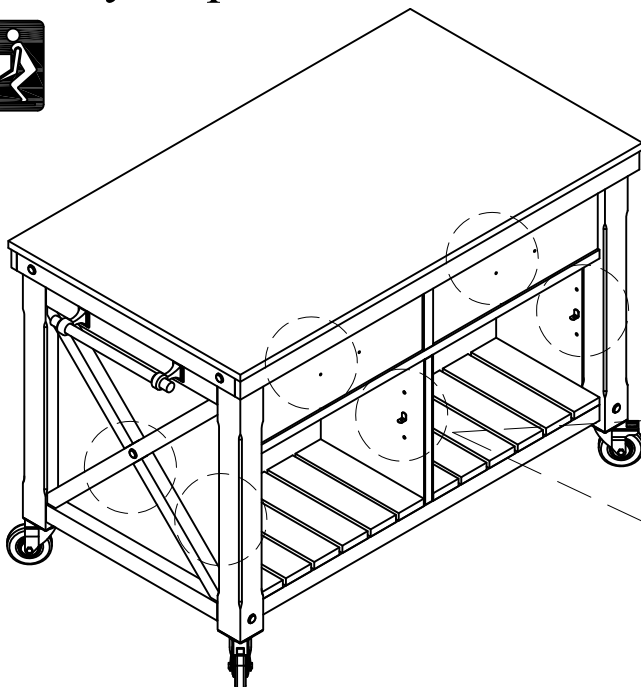

Assembly step 16

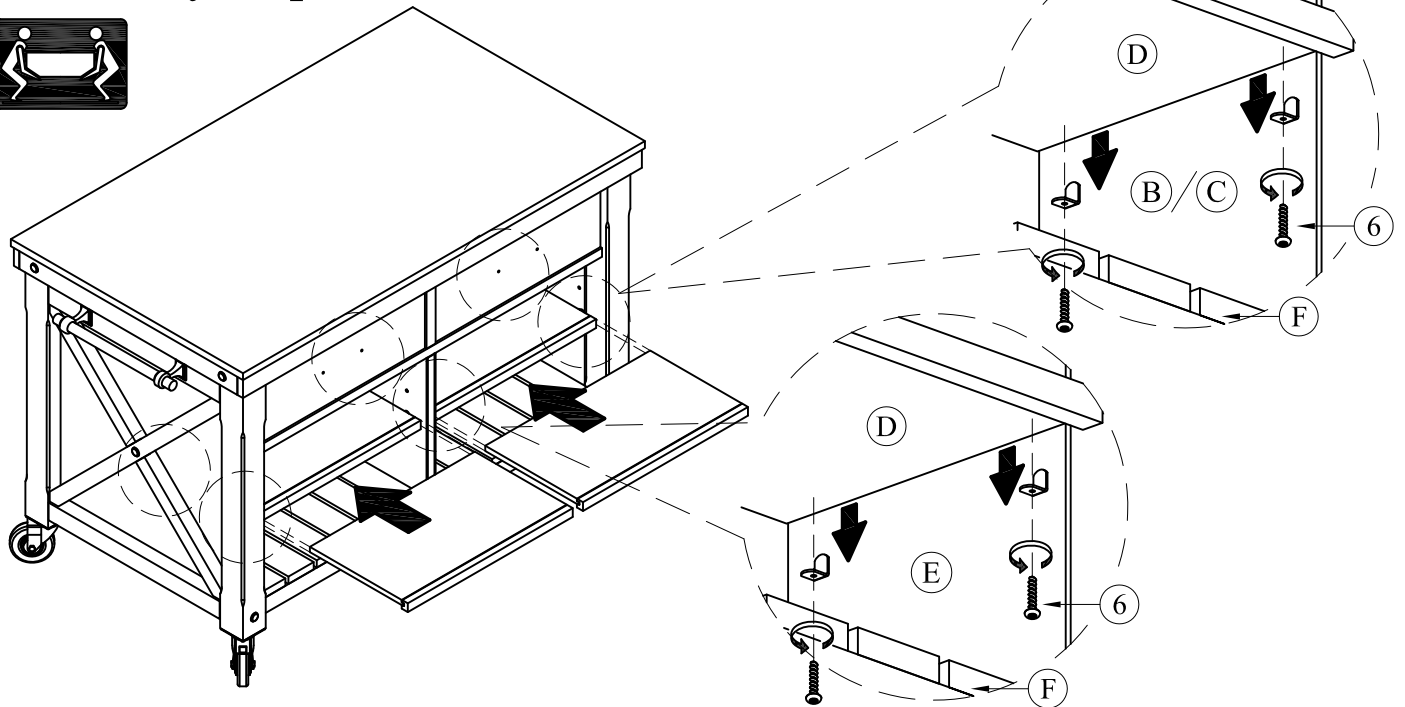

Assembly step 17

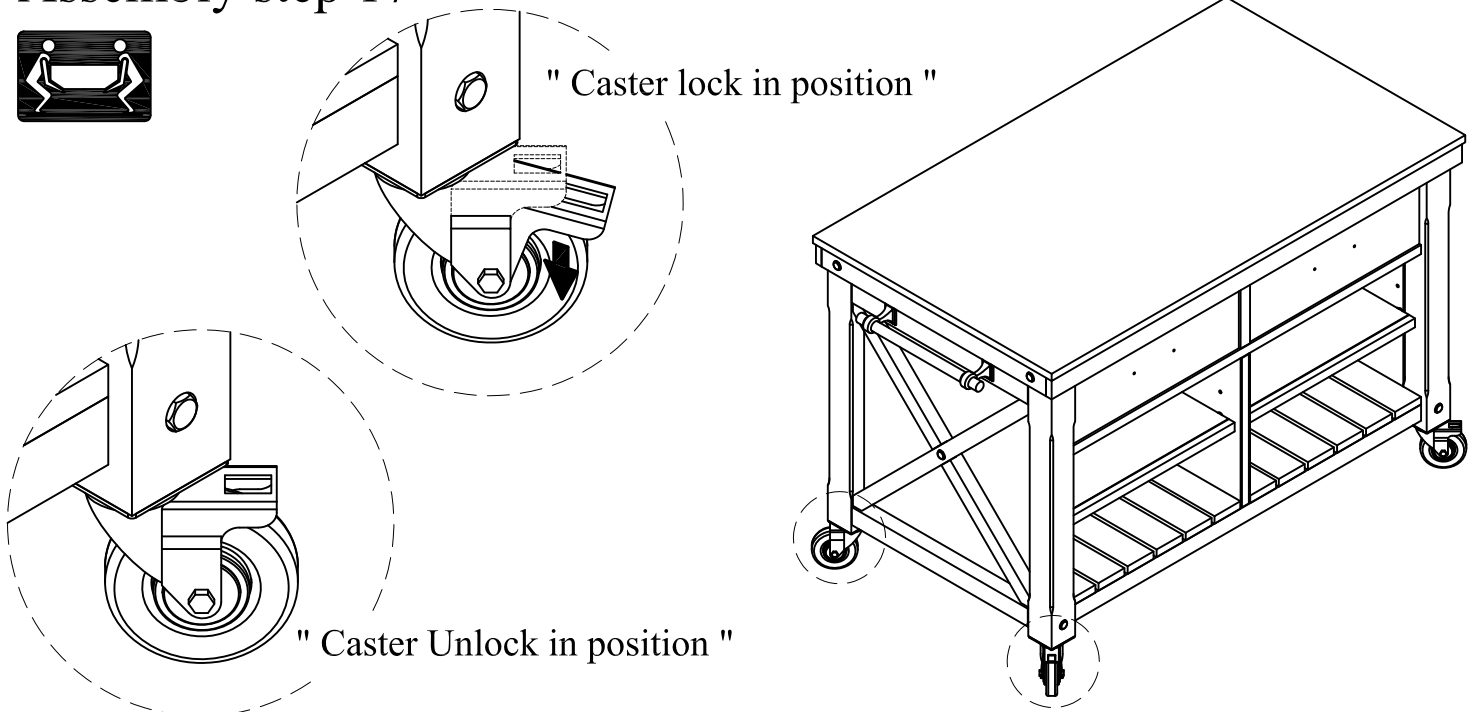

Assembly step 18

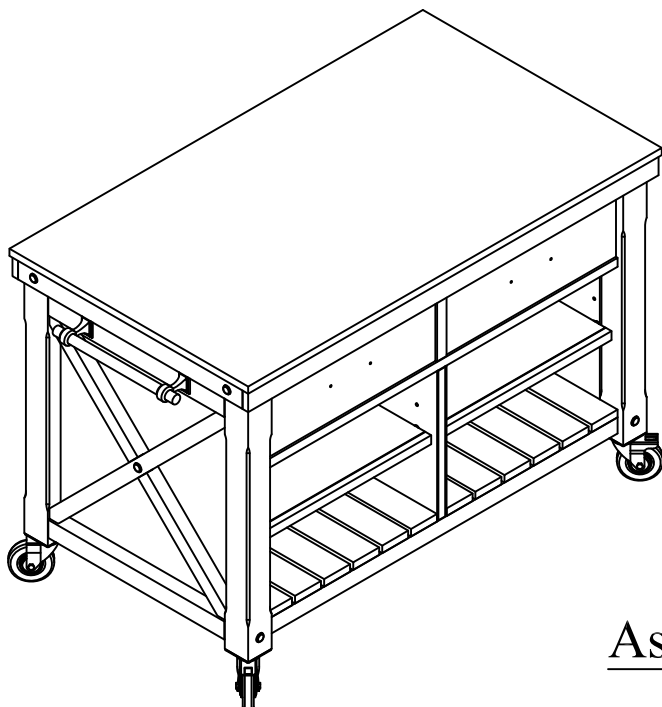

Assembly Completed